

CELEBRATING
25 YEARS
OF TRUST &
INNOVATION

ASTRAL
PIPES



*A consumer validated
Superbrand in piping category
for consecutive 4 years*



*India's Most Trusted Pipe Brand
based on TRA's Brand Trust
Report for the 5th time*

Power of Desire



*India's Most Desired
Brand based on TRA's Brand Trust
Report 2022*

ASTRAL
PIPES

CIN NO: L25200GJ1996PLC029134

Registered & Corporate Office: Astral Limited
207/1, 'Astral House', B/h Rajpath Club, Off S. G. Highway, Ahmedabad - 380059.
Ph: +91-79 6621 2000 | Fax: +91-79 6621 2121
E-mail: info@astralltd.com | Website: www.astralltd.com

For Export Inquiries: export@astralltd.com

ISO 9001 • 14001 • 45001
CERTIFIED COMPANY
By Bureau Veritas (India) Pvt.Ltd.



ASTRAL TOLL FREE
1800 233 7957

Please get in touch with us between 10 AM to 6 PM between
Monday to Friday and the last Saturday of the month.
We will remain closed on Public Holidays.

UNLOCK THE POWER OF EFFICIENCY

INTRODUCING
Thermoplastic Ball Valves



Compact True Union
Ball Valve

THERMOPLASTIC BALL VALVES



INTRODUCTION

Astral compact series True Union ball valve is designed with state of the art manufacturing technology and cutting edge features. It is one of most advanced compact series valve currently available in market. The valve is designed for all residential, commercial and many industrial applications. The valves are extremely smooth in operation with low operating torque values and fully pressure rated to give trouble free service with long life. The compact series valves are our effort to provide best solution to industry with high performance achieved by using industry best components like PTFE seats and FKM / EPDM rubber rings / gaskets.

The valves can be removed from its position very easily and can be fully serviceable due to its double union design. The compact series valves passed through strict quality control program and each and every valve is tested with low and high pressure which guaranteed the trouble free operating in all service conditions.

The valves are available in both uPVC and CPVC material which compliments our range of piping systems – Astral Aquarius Plus and Astral Chempro. With addition of this, Astral will be the leading one step solution for your complete piping needs.

APPLICATION AREAS

- Chemical process industries
- Life science industries
- Microelectronics
- Measurement and control technology
- Water treatment plants
- Food and beverage industries
- Shipbuilding

PRODUCT DETAILS

- **Size:** ½" - 2" (15mm to 50mm)
- **Material:** uPVC, CPVC, PP Handle
- **Joint End:**
 1. Flanged
 2. Socket(IPS/Metric)
- **Seat:** PTFE
- **Seals:** EPDM Or FKM
- **Pressure Rating:**
 1. 235 PSI (16kg/cm²) @ 73°F for Socket type
 2. 150 PSI (10kg/cm²) @ 73°F for Flange type



STANDARDS

ASTM D 1784 | ASTM D 2467
ASTM F 439 | ASTM F 1970

FEATURES

SYMMETRICAL HANDLE

The handle design is symmetrical which provide easy grip of valve and facilitate easy open / close positions

SEAT CARRIER ADJUSTMENT

Seat carrier adjustment can be performed by removing the strip (top part of handle). No need for any extra tools.

SEAT CARRIER DESIGN

Seat carrier design is one of the industry best with more number of threads. This ensures the high pressure sustain capabilities during the operating conditions.

DOUBLE STEM RINGS

The stem is having double o rings through which excellent leak protection is achieved. Also the stem groove is machined which gives highest degree of dimensional accuracy

FULL BORE DESIGN

The valves are designed with full bore discharge hence the flow as per nominal diameter is assured.

ERGONOMIC SHAPE

The overall shape of the valve is ergonomically design which helps easy handling / tightening of nuts.

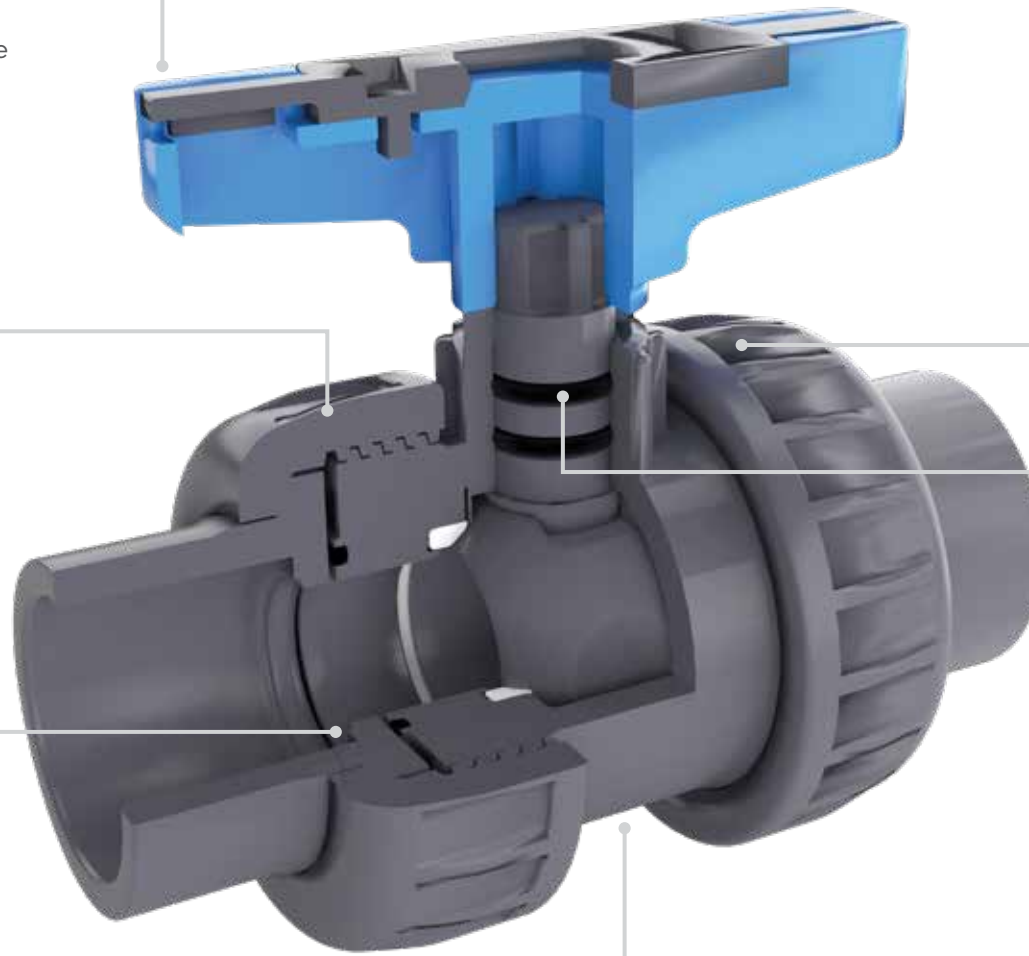

DIMENSION TABLE

Inch	L [MM]	D [MM]	H [MM]	H1 [MM]	H2 [MM]
1/2"	104	53	83	57	26
3/4"	114	61	97	66	31
1"	129	70	108	73	35
1-1/4"	141	84	125	83	42
1-1/2"	161	101	146	95	51
2"	181	120	173	113	60

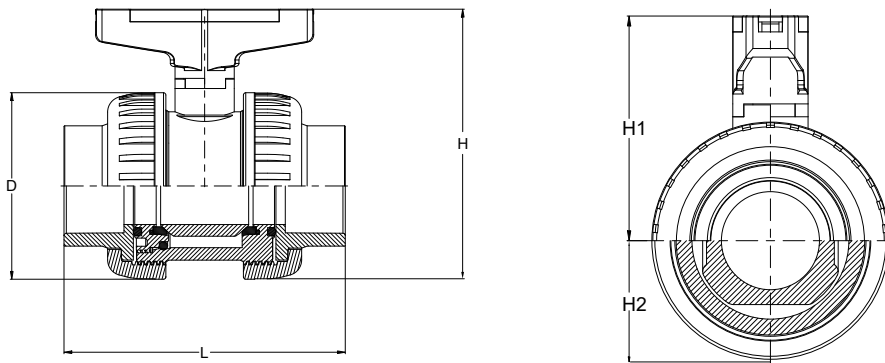

TEMPERATURE PRESSURE RATING

System Operating Temperature °F (°C)		100 (38)	110 (43)	120 (49)	130 (54)	140 (60)	150 (66)	160 (71)	170 (77)	180 (82)	190 (88)	200 (93)	210 (99)
Valve Pressure Rating psi (Mpa)	1/2"	235 (1.62)	211 (1.45)	150 (1.03)	75 (0.52)	50 (0.34)	-0- (-0-)	-0- (-0-)	-0- (-0-)	-0- (-0-)	-0- (-0-)	-0- (-0-)	-0- (-0-)
	2"	235 (1.62)	219 (1.51)	170 (1.17)	145 (1.0)	130 (0.90)	110 (0.76)	90 (0.62)	80 (0.55)	70 (0.48)	60 (0.41)	50 (0.41)	-0- (-0-)

COMPACT TRUE UNION BALL VALVE

ASSEMBLY PARTS

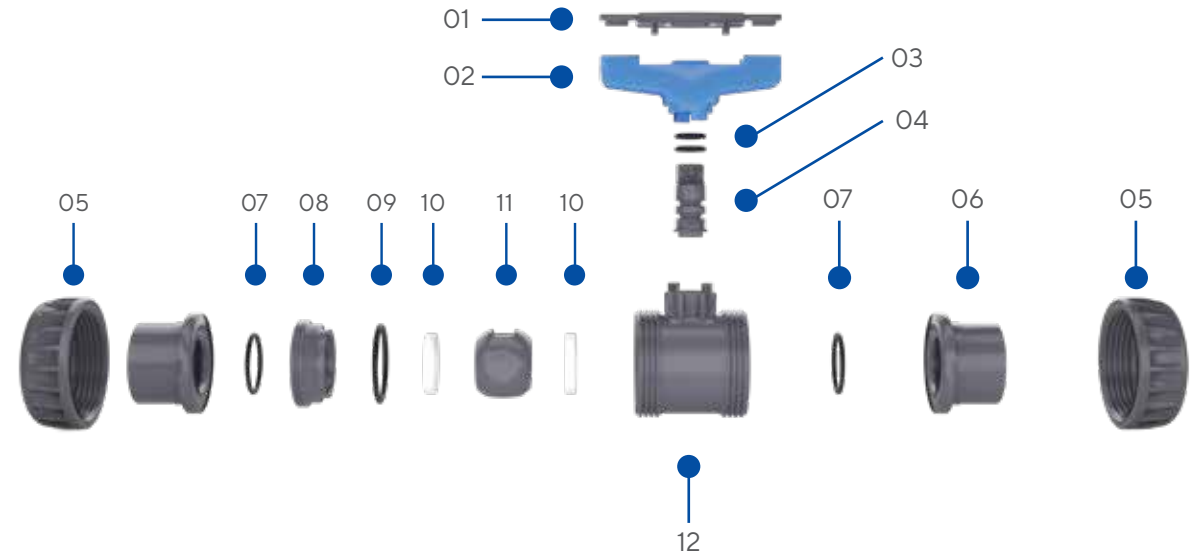

NO.	COMPONENT	QTY.	MATERIAL
1	Key for opening	1	PVC/CPVC
2	Handle	1	PP
3	Stem O ring	2	EPDM/FKM
4	Stem	1	PVC/CPVC
5	Union Nut	2	PVC/CPVC
6	Socket	2	PVC/CPVC
7	Socket seal O ring	2	EPDM/FKM
8	Seat Carrier	1	PVC/CPVC
9	Body Seal O ring	1	EPDM/FKM
10	Ball Seat (Teflon)	2	PTFE
11	Ball	1	PVC/CPVC
12	Body	1	PVC/CPVC